

New requirements for the relief in the topographic databases of the Institut Cartogràfic de Catalunya

Blanca Baella, Maria Pla
Institut Cartogràfic de Catalunya
Parc de Montjuïc
E-08038 Barcelona
<http://www.icc.cat>
blanca.baella@icc.cat
maria.pla@icc.cat

Introduction

The Institut Cartogràfic de Catalunya (ICC) is a public law entity of the Generalitat de Catalunya, the Autonomous Government of Catalonia. From its creation in late 1982, the ICC has focused its efforts in the cartographic production in Catalonia either in promoting the studies to improve the production workflows.

Since 1983 the ICC has been collecting information for the generation and for the updating of topographic products, including databases, digital terrain models, orthoimages and maps. At scales up to 1:25.000, data is mainly collected using photogrammetric systems, and stored as 2.5D data models. Since the acquisition of the digital camera in 2004, the complete workflow is digital.

In the year 2002, the ICC acquired an airborne LIDAR system, which represents another source of elevation data. At the moment, its main use is for estimating the risk of floodings. Another area of application is the improvement of elevation data in zones where photogrammetry doesn't reach the desired accuracy because poor or no visibility of the ground as it is often the case in zones such as forests covered by dense vegetation in mountainous areas.

Finally, there are a whole set of new requirements that the traditional topographic data models and the derived DTM and DSM need to fulfill for a wider exploitation of the enormous amount of existing elevation data. Some examples are the derivation of topographic products at smaller scales by automatic generalization, the improvement of the DSM to optimize orthophoto production workflows, the integration of LIDAR data to refine the existing models, or the enhancement of the cartography at 1:1000 for deriving appropriated DSMs for high resolution orthophoto (10 cm pixel) or for city models.

The relief in the ICC Topographic databases at large scales

The two ICC topographic databases of interest for terrain modeling are the Topographic Database at 1:5000 (BT-5M) and the cartography at 1:1000 scale. The ICC also produces the Topographic Database at 1:25000 scale, but the detail is too generalized to achieve the 1,5 m RMS accuracy required for ICC's master DTM

The Topographic Database at 1:5000 scale

The Topographic Database at 1:5000 scale is the most detailed database that covers Catalonia. The data is compiled using photogrammetric systems according to a 2.5D data model. The accuracy is 1 meter RMS for X and Y and 1.5 meters RMS for Z. The updating cycle is 5 years over all the country and more frequently over the most dynamic areas. During the stereoplotting process all the features required to generate a DTM and a DSM are compiled together with the topographic objects.

Both the DTM and DSM are in triangle or grid format, depending on the capabilities of the application software used and the final product to be obtained.

The features collected on purpose for the DTM generation are scan lines, break lines, spot heights, contour lines used to infer break lines, and flat areas. Moreover all the planimetric features captured on the ground are used as break lines. The main use of DTM is to derive the contour lines and the shaded relief at smaller scales.

For orthophoto rectification at large scales, the DSM is used instead of the DTM because of the problems when there are differences between the terrain and the actual elevation. This is the case, for example, of buildings or bridges (Figure 1). The features for the DSM include all the features collected for DTM excluding the areas covered by buildings or bridges, where their elevation substitutes the terrain. Some processes are required to generate special data to avoid vertical triangles, which are not supported by most of the software available.

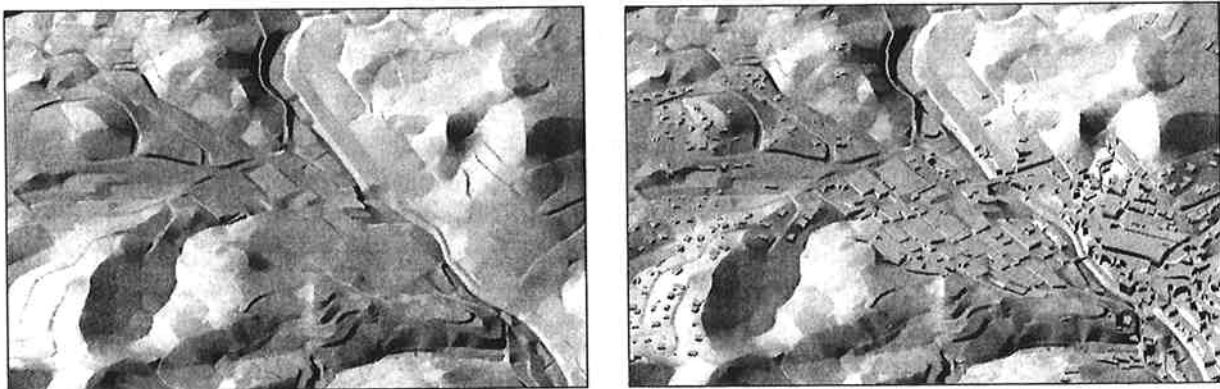

Figure 1. The images show the differences between DTM and DSM

The altimetric data is checked during data capture by running quality control processes that apply different techniques to detect and correct mistakes. The digital photogrammetric systems allow the superimposition of stereo images and vector data, and this is a powerful tool to detect severe mistakes. Checking the height of the intersection of crossing break lines or contour lines allow to queue and correct the elevations at the erroneous intersection points. Also, the generation of contour lines allows analyzing the result of the interpolation of these elements. Finally, the shaded relief provides an idea of the quality of the model and helps to detect small errors. All these verification processes can be repeated until the data becomes acceptable.

The Cartography at 1:1000 scale

The Cartography at 1:1000 scale covers the urban areas and the areas planned for urbanization. The data is compiled photogrammetrically and it is completed by data surveyed on the field. The accuracy is 20 centimeters RMS for X and Y and 25 centimeters RMS for Z. The updating cycle is approximately 5 years. Although the data model is 2.5D, it is not designed to generate neither a DTM nor a DSM. The relief is represented by contour lines and spot heights as in the traditional cartography at this scale.

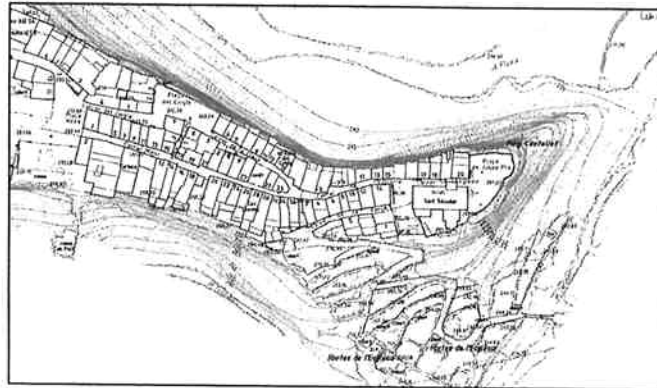

Figure 2. The image shows a detail of Cartography at 1:1000 scale

The relief derived from the ICC LIDAR data

In 2001, the ICC acquired an Optech ALTM 3025E airborne laser scanner (LIDAR), which started production in February 2002. The current state of the art of this technique allows for measuring the distance traveled by the laser beam to the centimeter level precision, although the GPS and INS errors reduce this precision to 15 centimeters in normal operating conditions.

Very recently, the ICC has acquired an ALS 50-II LIDAR from LEICA GeoSystems that is about to enter production.

Some examples of applications are flood risk analysis, mapping of power lines, management of forest areas, analysis of the changes in the shore line, change detection in urban areas and as primary segmentation criteria for multispectral classification.

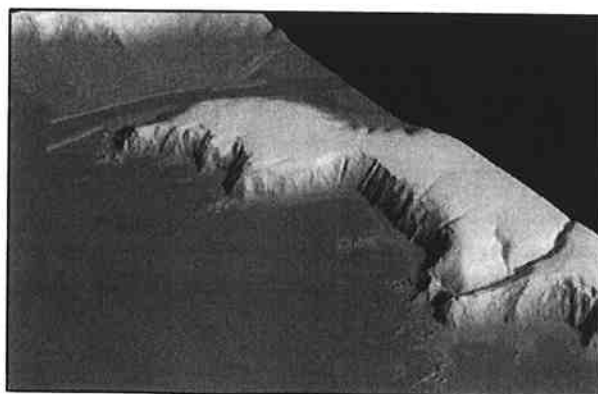

Figure 3. Shaded relief derived from LIDAR data

New ICC applications based on elevation data

Spot heights generalization

Since 1997 the ICC has been applying automatic generalization techniques in the production workflows of the vector topographic databases and maps, but these techniques never have been used on the objects that characterize the relief. The main reason is that the available commercial software has not offered, until now, any tool specifically designed for relief generalization.

From 2002 the Research Group of Geoenvironmental Cartography and Remote Sensing of the Department of Cartographic Engineering, Geodesy and Photogrammetry of the of the Universitat Politècnica de València (UPV) has developed the GENCOTES application for generalizing spot heights. The main principle behind this software is the analysis of the morphology of the terrain (Palomar and Pardo, Vall de Núria, 2004) while taking into account cartographic aspects such as the significant points or the map names.

In 2006, the ICC and the UPV signed a collaboration agreement for adapting GENCOTES to the cartographic production environment of the ICC. As a side effect of the geomorphologic analysis of the terrain, the original data would be enriched with the classification of the spot heights.

The ICC decided to apply this tool to the generalization workflow that produces the Topographic Database of Catalonia at 1:25,000 scale from the master database, the Topographic Database of Catalonia, at 1:5,000. Until before, the generalization operations applied on contour lines have been automatic selection and point filtering, followed by manual revision and editing of the conflicts, and in the case of the spot heights, the generalization has been done totally by manual processes. The main reason for start using GENCOTES on the 1:25000 generalization workflow was the significant number of spot heights that must be present on a map at this scale requiring a costly manual generalization.

GENCOTES automatically generalizes the spot heights in two steps: a hierarchical classification of the spot heights for giving a specific value to each one based on parametric criteria, and a selection taking into account the hierarchical classification and a balanced distribution of these points on the final data. In terms of hierarchy, three kinds of spot heights are considered:

- a) Special interest points. Defined by the specifications as significant, must remain in the generalized data (for example, on the roads, related with map names, etc.).
- b) Geomorphologic interesting points. They identify characteristic terrain points, such as peaks, passes or depressions.
- c) Remainder points. All the other spot heights that have not been considered in the previous categories.

Although the results with ICC data were really promising, some modifications were introduced for taking into account the complete set of the ICC rules and to obtain results more similar to the manual generalization.

The altimetric point generalization obtained using GENCOTES is in some aspects lightly different from the manual generalization. The differences come from the difficulty of

describing and specifying all the contextual and aesthetical rules that the cartographers apply during manual generalization. Nevertheless, the results were good enough to implement the tool into a real cartographic production environment. Results show an improvement in terms of global homogeneity and an effective time saving without a loss of quality. Moreover, the geomorphologic classification of the original spot heights will be used to enrich the original database and it will be exploited in further applications of terrain generalization or terrain analysis.

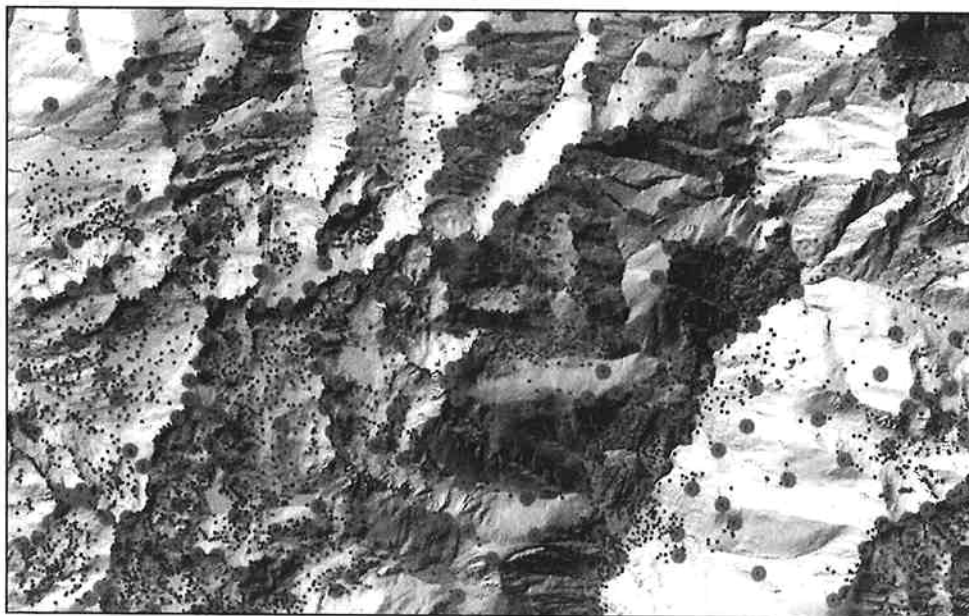

Figure 4. The result of automatic generalization on the complete map sheet, corresponding to a high mountain area in the centre of Pyrenees: original spot heights in red and the result of the automatic generalization in green

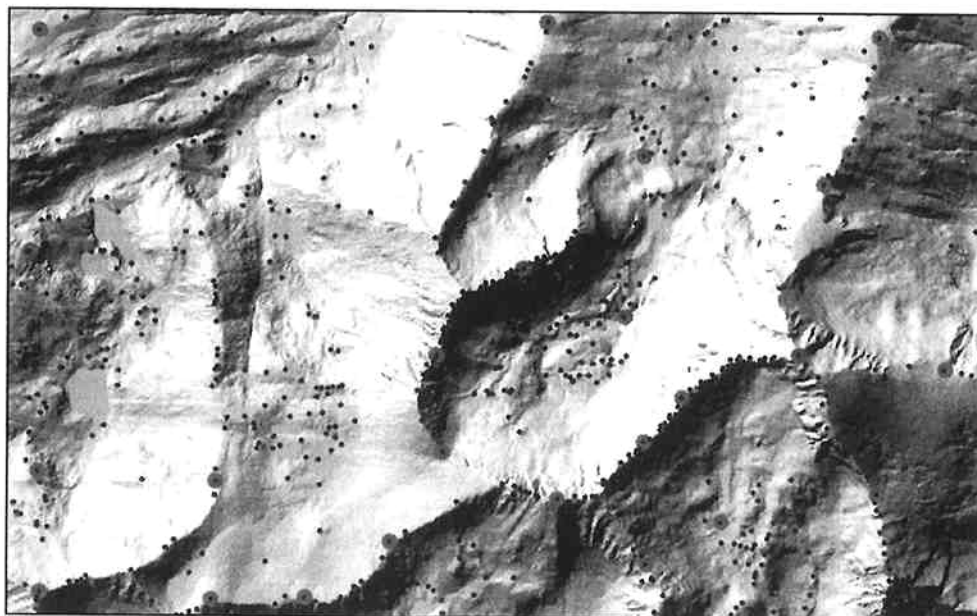

Figure 5. An enlarged view of the results (10 km²).

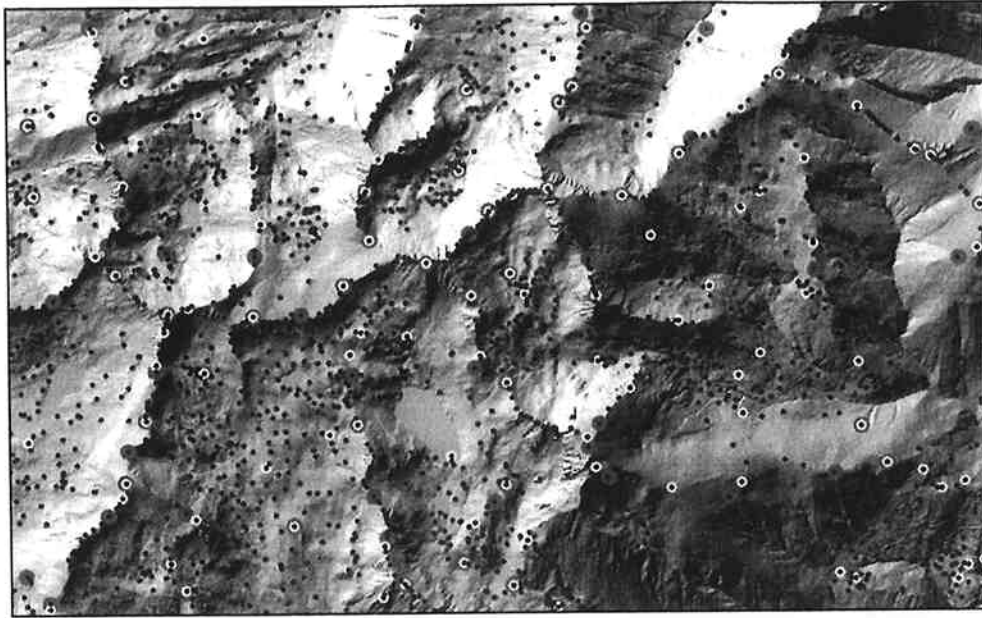

Figure 6. The original spot heights in red, the manual generalization in yellow, and the automatic generalization in green (40 km²).

The new data model for the Cartography at scale 1:1000: DTM and DSM generation

From its creation, the ICC has been covering Catalonia with orthophoto images at 1:5000 scale, with pixel of 50 centimeters, using internally developed software that is constantly improved. The updating cycle has been reduced to 2 years and an annual coverage is to start in 2008. In the most populated areas, the ICC is also producing orthoimages with pixel of 20 centimeters.

Increasingly, a larger number of users are asking for higher resolution (10 cm) and accurate orthophotos in urban areas. As it is known, the main problem for high resolution orthophotos is the availability of a good and accurate DSM.

A DSM can be obtained by stereoplotting of contour lines, scan lines, break lines and spot heights, by applying photogrammetric automatic image matching (correlation) or by using the direct measurements of a LIDAR system. Correlation and LIDAR data require manual quality checking and editing to add break lines and control points to the model, specially in built up areas, bridges, walls, embankments, cliffs and plain water and also in areas of poor texture in the case of correlation or too dense vegetation in case of LIDAR.



Figure 7. The top image shows a detail of an orthophoto rectified using a DSM obtained from LIDAR data. The bottom image shows the result using a DSM obtained by stereoplottting

As the ICC has mapped almost the full coverage of the urban areas of Catalonia at 1:1000 scale, the generation of urban DSM from stereoplottting is the most feasible option from both a technical and economical point of views. However, and as mentioned before, although the 1:1000 maps are 2.5D, the elevation data were not designed to generate neither a DTM nor a DSM (Figure 8, top).

Therefore, the old model has been improved by adding the elements required for the computing of an adequate elevation model for large scale orthophotos. The changes include the classification of the elevated sections of some linear elements (roads and railways over bridges), the selection of the elements collected on the ground that must be considered as break lines, the generation of polygons for buildings and constructions (Figure 8, bottom) and the compilation of auxiliary element to properly model bridges and tunnels.

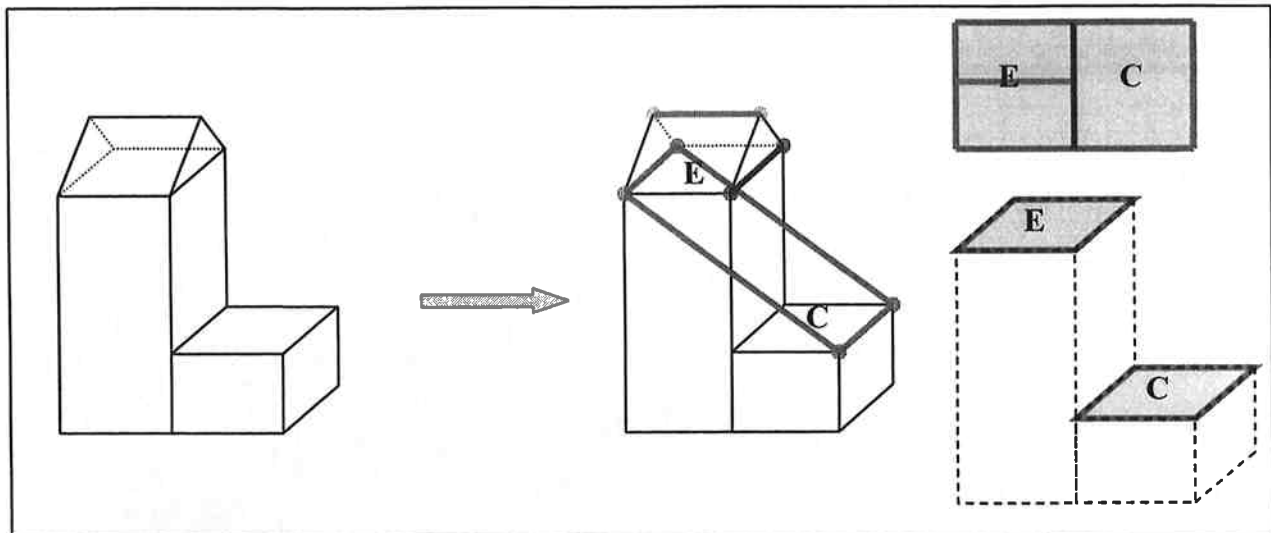
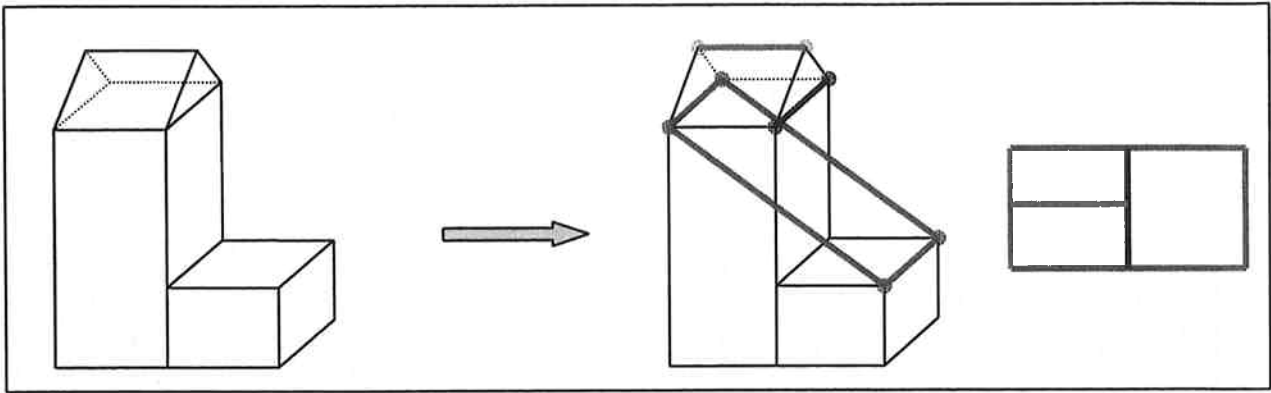

Figure 8. The top picture shows how the data is compiled in the old model at 1:1000 scale.

Red lines represent the roof edges, blue line represents the ridge top line and green line represents the top of roof cornice. The bottom picture shows the improved model by adding the generation of flat polygons for the buildings at the cornice height

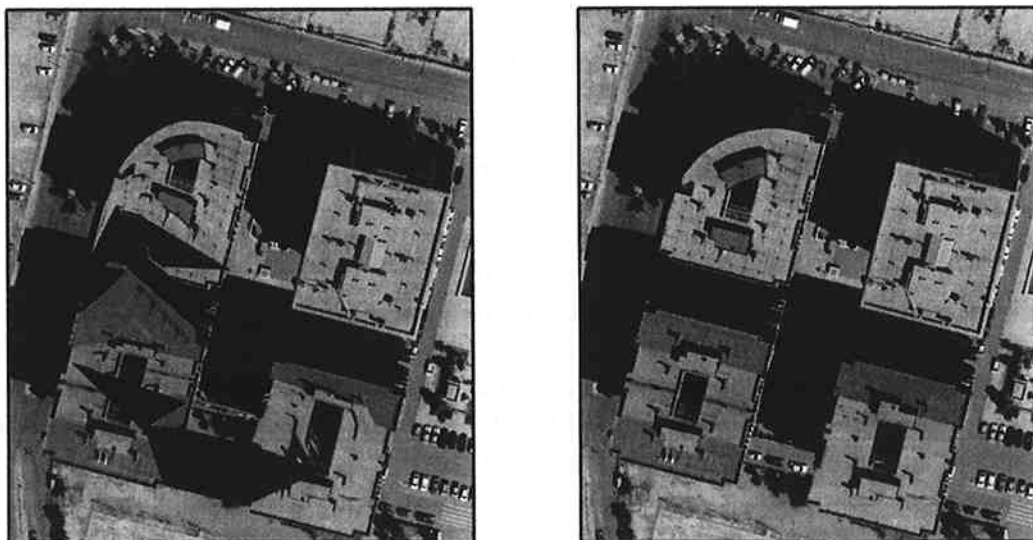

Figure 9. The improved model allows for a correct orthophoto rectification. Left image shows the result using the old model and the right image shows the result after the improved model

ICC challenges related with elevation data

The ICC has a complete and updated elevation coverage of Catalonia. Further applications of these data require to additional enhancements such as a more detailed classification of the break lines, or the use of LIDAR data to refine the accuracy of the master elevation database.

Classification of the break lines

As mentioned before, while stereoplotting of the Topographic Database at 1:5000 all the objects needed for generating the DTM and the DSM are compiled at the same time as the topographic objects. The features collected on purpose for the DTM are scan lines, break lines, spot heights, contour lines used to infer break lines and flat areas. Moreover all the planimetric features captured on the ground are used as break lines. The break lines which are not coincident with planimetric elements are not classified, for example, the break line collected on the bottom part of an embankment has the same classification that a break line collected to represent a ridge.

The poor classification of these break lines is not a problem for the master elevation model generation, but it does limits further exploitations, such as generalization for smaller scales (1:25.000 or 1:50.000) or the selection of specific break lines to enrich the LIDAR data.

The results of GENCOTES have encouraged the ICC and the UPV to continue their collaboration to apply a similar methodology for automating the classification of break lines. So far, there are some preliminary results on a test area, and during this year a prototype will be developed.

The use of LIDAR data to refine the existing elevation data

Comparisons of the LIDAR DTMs with the photogrammetric BT-5M DTMs has been done several times by analyzing the differences of 1 meter grids derived from both datasets. The results show that the BT-5M achieves the nominal accuracy in elevation, except in the dense forested areas.

The following example shows the comparison on 2 areas, one in a very flat terrain in a delta river (Delta de l'Ebre) and another one in a mountainous area covered by a dense forest (Garrotxa).

Delta area

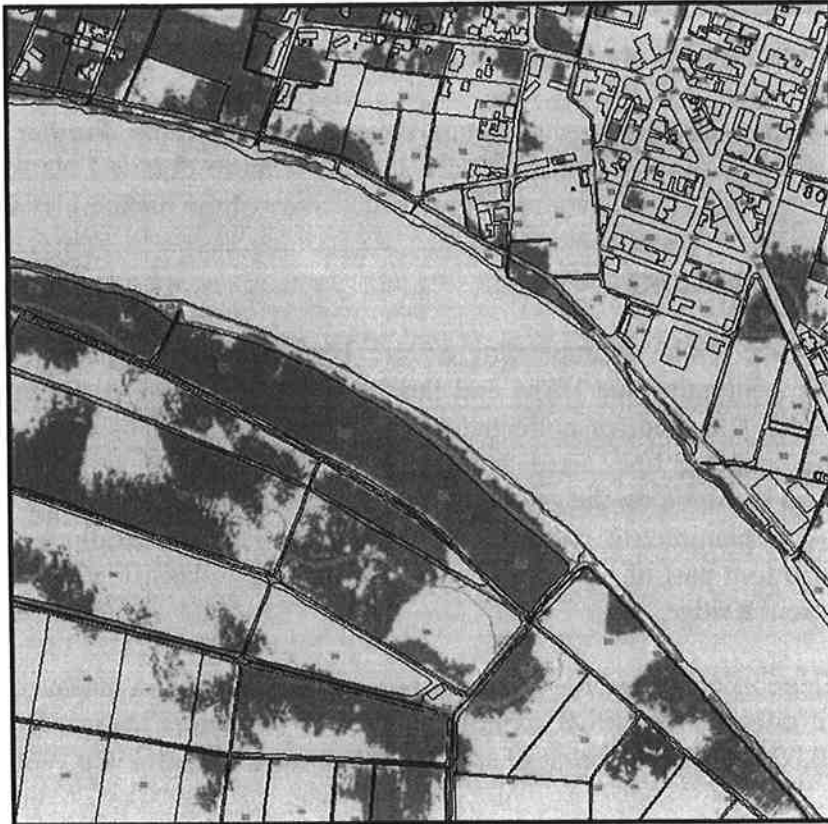

Figure 10. Differences between elevation data in the Delta de l'Ebre area. The violet color indicates that the BT-5M data is above the LIDAR data by between 0 and 1.5 m. The rose colour indicates that the BT-5M data is under the LIDAR data by between 0 and 1.5 m. The red colour indicates that the BT-5M data is under the LIDAR data between 1.5 and 3 m.

Delta de l'Ebre	dz
Points	1.038.361
RMS	0.376
Maximum error	1.300
Minimum error	-2.883
90% points	0.519

In the delta area there are no occlusions. The differences higher than 1 m are sparse and usually due to the different flight mission date or due to some problems in a LIDAR data filtering. For example, because of small hummocks or rough terrain smoothed or eliminated because it has been confused with vegetation. It can be considered that the elevation data obtained from the BT-5M has the expected accuracy in this very flat area.

Mountainous forest area

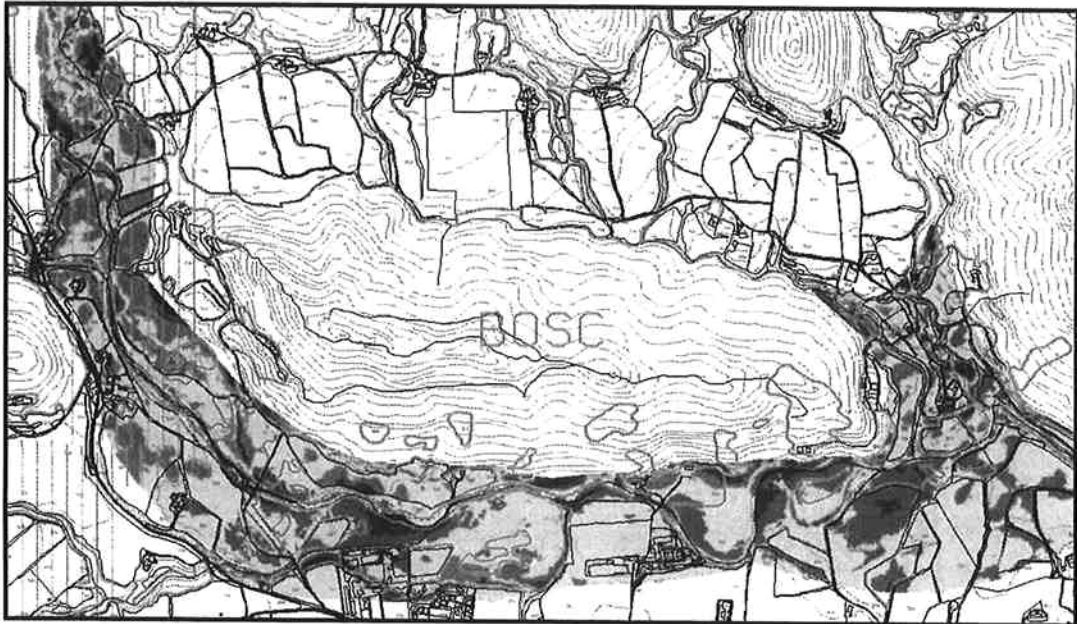

Figure 11. Differences between elevation data in forest areas. The violet colours indicate that the BT-5M data is above the LIDAR data in intervals of 1.5 m. The rose and red colours indicate that the BT-5M data is under the LIDAR data in intervals of 1.5 m

Garrotxa	dz
Points	1.693.111
RMS	1.378
Maximum error	10.184
Minimum error	-7.253
90% points	1.960

Quite often, in forested mountainous area, the stereoplottling operator can not see the ground and therefore it is not possible to achieve the expected elevation accuracy. The result is that the differences between the LIDAR and the BT-5M elevations are larger than 1.5 m in the forested areas.

After analyzing the previous results, it has been decided to use the LIDAR data to correct the master DTM in the dense forest areas. Consequently, we are now covering all Catalonia with LIDAR data and preparing a workflow for integrating both datasets.

References

- J. Palomar, J. Pardo. *Generalization of height points in trail maps*. Proceedings of 4th ICA Mountain Cartography Workshop, 30th September - 2nd October 2004, Vall de Núria.
- B. Baella, J. Palomar, J. Pardo, M. Pla. *Deriving the relief of the Topographic Database of Catalonia at 1:25,000: spot heights generalization from the master database*. 7th ICA Workshop on Progress in Automated Map Generalization, 2-3 August 2007, Moscow

